

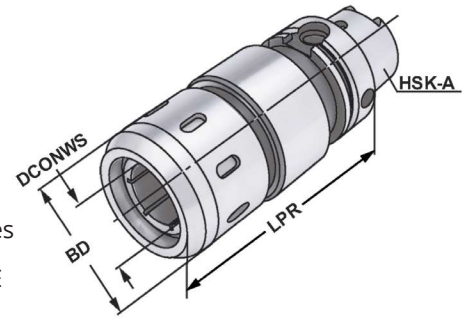

**Verwendung:**  
Zur Aufnahme von Werkzeugen mit Zylinderschaft nach DIN 1835 Form A+B+E und DIN 6535 Form HB+HE

**Application:**  
For mounting straight-shank tools acc. DIN 1835 form A+B+E and DIN 6535 form HB+HE

**Application:**  
Destiné à recevoir les outils avec les queues de forme cylindrique suivant DIN 1835 en forme A+B+E et DIN 6535 en forme HB+HE



ISO  
12164

Form  
A

$\leq 3\mu\text{m}$

$G6.3$   
15.000  
min<sup>-1</sup>

RFID  
Chip

HKS

13.04

5

Bestell-Nr. Order no. Référence	HSK	DCONWS Spannbereich Capacity   Capacité	Typ	DCONWS	LPR	BD
A63.64.20	HSK-A 63	3 - 20	HKS 20	20	95	53
A63.64.25	HSK-A 63	3 - 25	HKS 25	25	100	63
A63.64.32	HSK-A 63	3 - 32	HKS 32	32	110	68
A100.64.20	HSK-A 100	3 - 20	HKS 20	20	105	53
A100.64.25	HSK-A 100	3 - 25	HKS 25	25	105	63
A100.64.32	HSK-A 100	3 - 32	HKS 32	32	105	68

Größe Size Taille	20mm	25mm	32mm
Anzugsmoment Clamping torque Couple	50-70 Nm	80-100 Nm	80-100 Nm
Spannkraft Clamping force Tension	780 Nm	2000 Nm	2000 Nm

